

Good

Our Potential

Free Will

Openness

Balanced
Exchange
System

True Capitalism

Diversity

THE BASICS

Ownership

Monetary
System

Capital

Government

Corporation

Corruption

Universal Basic
Income

Conspiracy

Evil

MICHAL BRATOWSKI

This publication may be freely copied, reproduced and transmitted.

December 2020

Contents

Introduction.....	1
Free Will and Freedom	2
Natural Laws	2
Our Potential	2
Choice of Good vs Evil	2
Living in Groups	3
Possible Worlds.....	4
Diversity	5
Minorities	6
People and their Impact.....	7
Openness or Conspiracy.....	8
Capital	10
Current Definition	10
Correct Definition	10
Our Hidden Power – True Capital.....	10
True Capitalism	10
Producers and Consumers.....	11
When We Are Producers and When We Are Consumers.....	11
The Role of Producers.....	11
Balance and External Factors.....	12
Limitations in Today’s System	12
Unrestricted System	12
Current Monetary System	13
Naturally Evolved or Imposed	13
The Illusion and Monopoly	13
Prosperity and Crisis	14
Theft of Our Capital and Wealth.....	16
Possible Monetary Systems	17
Government Control.....	17
Competition.....	17
Corruption.....	18

Corrupt People.....	18
Corrupt System.....	18
How to Fix Corruption	19
Public Services	19
Paradigm Shift	20
Take Ownership of Your Life	20
No Need for Money.....	20
Creative Approach.....	20
Balanced Exchange System (BES)	21
The Principles.....	21
The Meaning of Balance	21
Unit of Measure.....	23
Benefits.....	25
Feasibility in Real Life.....	26
Try It at Home	27
Ownership.....	28
Shared Ownership	28
Cooperation Instead of Corporation	28
Government.....	29
Crowdfunding as Taxation	31
Public Services as Crowdfunding	31
Something for Socialists.....	32
Universal Basic Income	32
Government.....	32
Dynamic Control	33
Experts, Not Politicians.....	34
Council of Wisemen.....	34
Final Note.....	35

Introduction

I am an ordinary man like you, who is continuously trying to seek the truth, defend it, and share it with others. I have decided to share my thoughts on various aspects of our lives and the life of humanity as a whole. I have done this because I care. Some of you may not find anything revealing here, and I take it as a good sign because what I present in this book is what we all already know, but many of us have forgotten. If you know someone who has forgotten it, please share this book with them. I will be very grateful if you do.

Special thanks to my lovely children, who prepared the illustrations used in this book.

Free Will and Freedom

Natural Laws

We are born into this world naked and vulnerable, relying on our parents to keep us safe and let us grow. There is no guarantee of how long and how good our life is going to be. At this point, nobody knows who we are going to become and what we will do during our lifetime. It is a big unknown. This is where our journey starts, and we all want it to be a positive experience. Looking at a new-born, we often wonder what his or her life will be, and we wish the baby has a good one.

Our Potential

We can describe it as a potential. This potential is a combination of all possibilities of how this new life can explore and express itself. Each of us shows signs of our potential sooner or later, and we call them talents. We discover and develop our talents during our childhood by learning new things and skills, asking questions, and exploring the world around us. This further continues in our adult life, even though a lot of people assume that learning stops once we reach a certain age or status in life. We learn throughout our entire life. The whole process increases our potential, and it depends on us how much we progress and turn this potential into something useful.

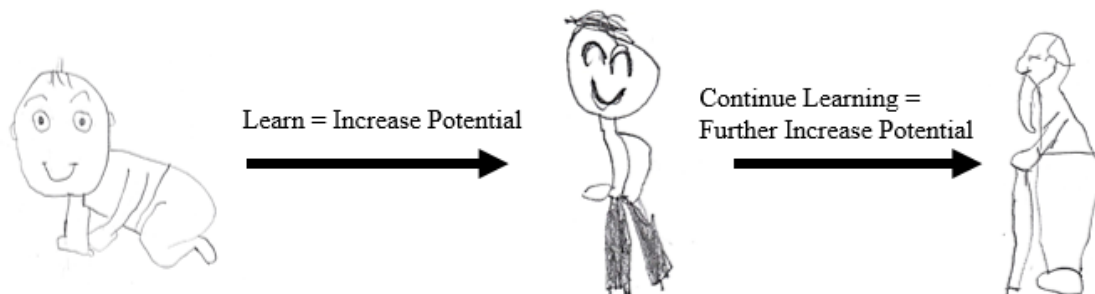

Figure 1

Choice of Good vs Evil

The experience that we call our life is a subject to the laws of nature and the objective truth. We do not fully understand or realise it; thus, we view our life as a sequence of often random events, some good and some others bad. We continuously make a number of choices being able to foresee only short-term results. We are shaped by our environment that imposes artificial limitations to our imagination and actions, and we often lose ourselves in the complexity of such a system to finally forget who we truly are.

However, we have free will, that is freedom of choice, and we can always choose between right or wrong, good or bad. Our life is full of such choices, and it is entirely up to us whether the

choices we make lead us towards good or evil. It is done through the conscious and consistent choice and determines how we are seen by others. Someone who knows the objective truth would be able to position us very accurately on a scale of good and evil. This position is continuously changing with every choice and action we take. The direction of changes is always reversible and depends on the consistency of our choices. We often describe people as good or bad based on our observations of their choices, actions, and how they affect others. We also assess ourselves in a similar manner. These are, however, subjective opinions. When I refer to a good or bad (evil) person further in this text, I mean it from the objective truth standpoint. This is for the purpose of analysis.

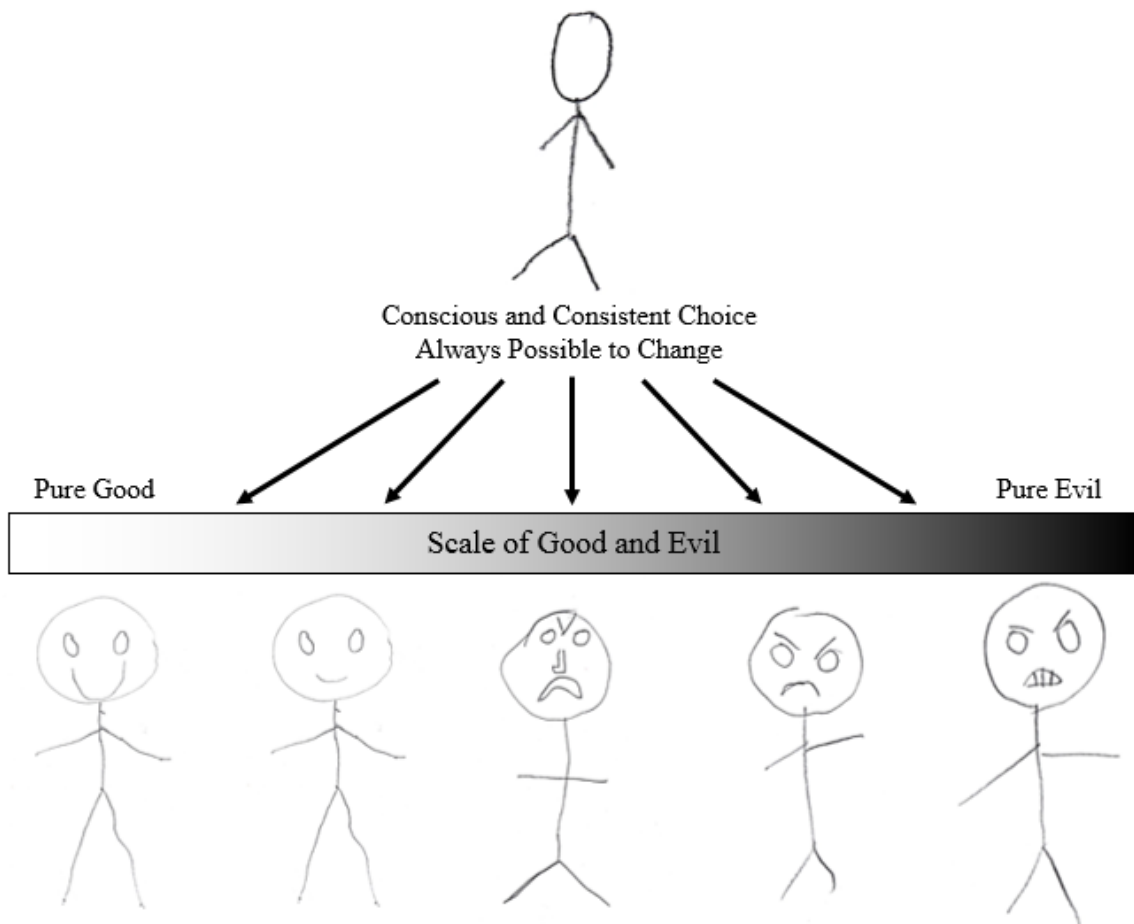

Figure 2

Living in Groups

Since we live in groups, our choices very much depend on and influence the interactions we have with other people. We can imagine how such interactions work between two good people, two people where one is good, and another one is evil, and two evil people. We can envision what the relationship between each of these extreme couples looks like.

In the case of a good-good relationship, there is harmony and cooperation even with differences because the people trust and respect each other. In the case of a good-evil relationship, there is a destructive factor of evil that introduces manipulation and desire to control the other. In this

relationship, the good person is likely to suffer from the evil, but this also depends on their awareness. In the case of an evil-evil relationship, there is full destruction through continuous manipulation and war.

Of course, in reality, none of us is purely good or evil, and at any point in time, each of us and each relationship we have with someone can be placed on the scale of good-evil. Our reality is, in fact, a mixture of all possible relationships between and including the extremes mentioned above.

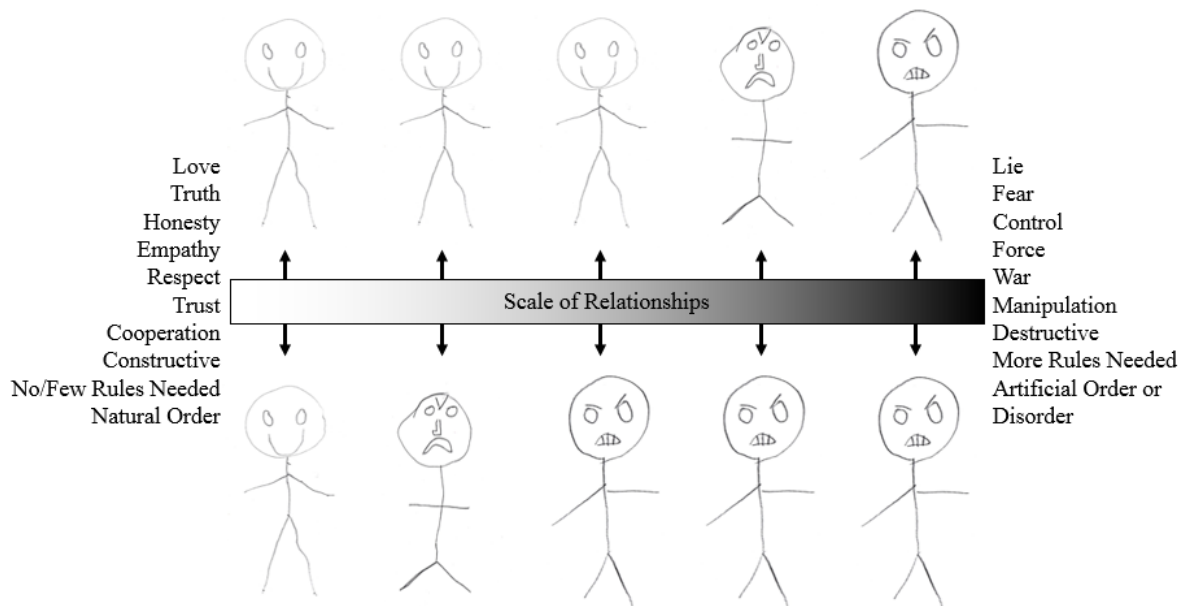

Figure 3

Possible Worlds

With billions of people and even more individual relationships between them, our world is the result of all the relationships and the dominant attributes that come from their predominant choices. Again, considering the extreme cases, we can think of two worlds. Between these extreme worlds, there is an unlimited number of possible worlds that combine the attributes of these two. It is important to realise this and the fact that any new human and any new generation of people come to this world at a specific moment of balance of these attributes. It becomes a reference point for them. Unless it is adjusted through learning about other (previous) worlds, it will be used by them as a standard for future comparisons. The world of good people is a natural world, where people have freedom and understand it very well. Everyone learns how to take responsibility for themselves and the consequences of their actions. People are free to express themselves and explore various possibilities. There is will to live in full and excitement about the undiscovered future. On the other hand, the world of evil people or where evil factor has significant influence is artificial. The world is presented as perfect, but this is only a façade that hides a system of control, obedience, and punishment for non-compliance. Evil is not necessarily visible, and when applied intelligently, it can create a fake world that on its surface

resembles the true, natural and wonderful world. It can trick good but naive people into accepting it.

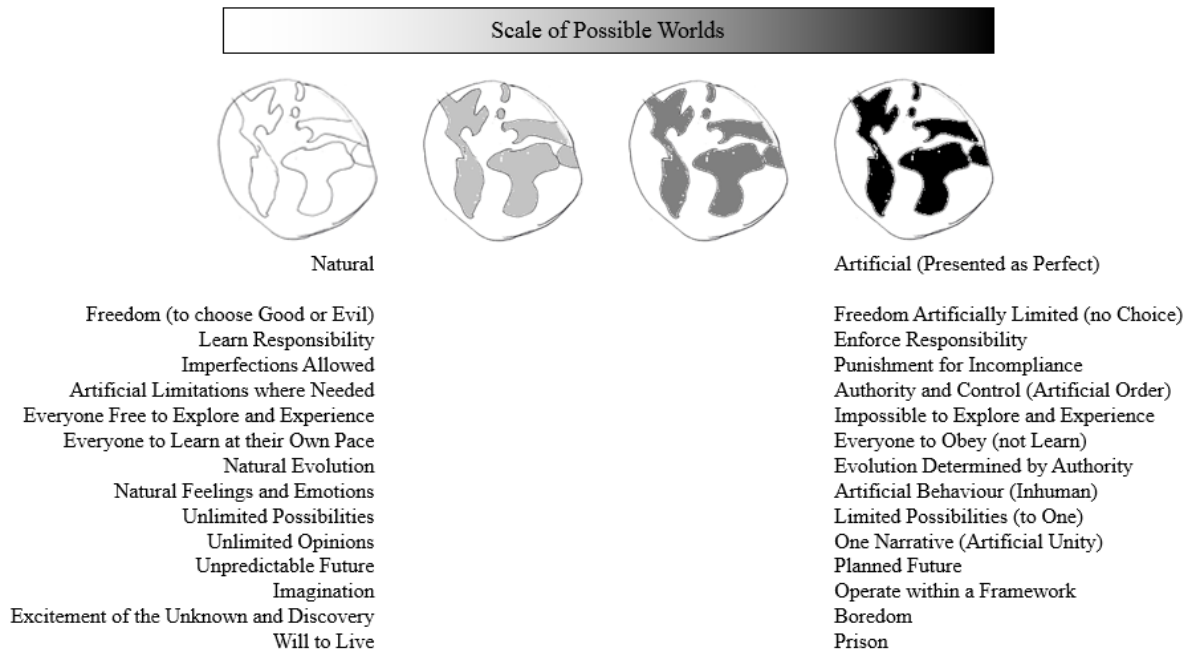

Figure 4

Diversity

Our world is diverse. We observe and identify various differences between each other and groups of people. As a result, we make a distinction by race, gender, age, nationality, religion, social status, political views and many others. There is nothing wrong with identifying such differences, but it is important what we do about it. We can imagine two scenarios of where this can lead us to, considering the relationships mentioned earlier.

Differences become a cause of conflict where an evil element exists. We all can see and experience it. In the relationship without evil factor, diversity is a great opportunity to learn from each other and understand different perspectives. Looking at it from a system point of view, it is a very efficient way of self-development. Please note that while you live your specific life (personal experience) by openly and honestly exchanging your views with another human, you can indirectly experience another life. Imagine how many lives you would have to live in order to experience and learn all this if you did not have such an opportunity. Moreover, diversity also allows various lives (people experiences) to interact with each other, which makes it even more complex than living each of these lives in isolation. Considering how many people you can meet in your lifetime and utilise this opportunity, we all seem to have unlimited potential to learn and grow. Together, we can advance the world very quickly and efficiently as long as we use diversity constructively.

If we look at diversity as a threat because we focus our attention on differences that we are afraid of exploring and learning about, then we tend to destroy each other and our own opportunities to grow as humans.

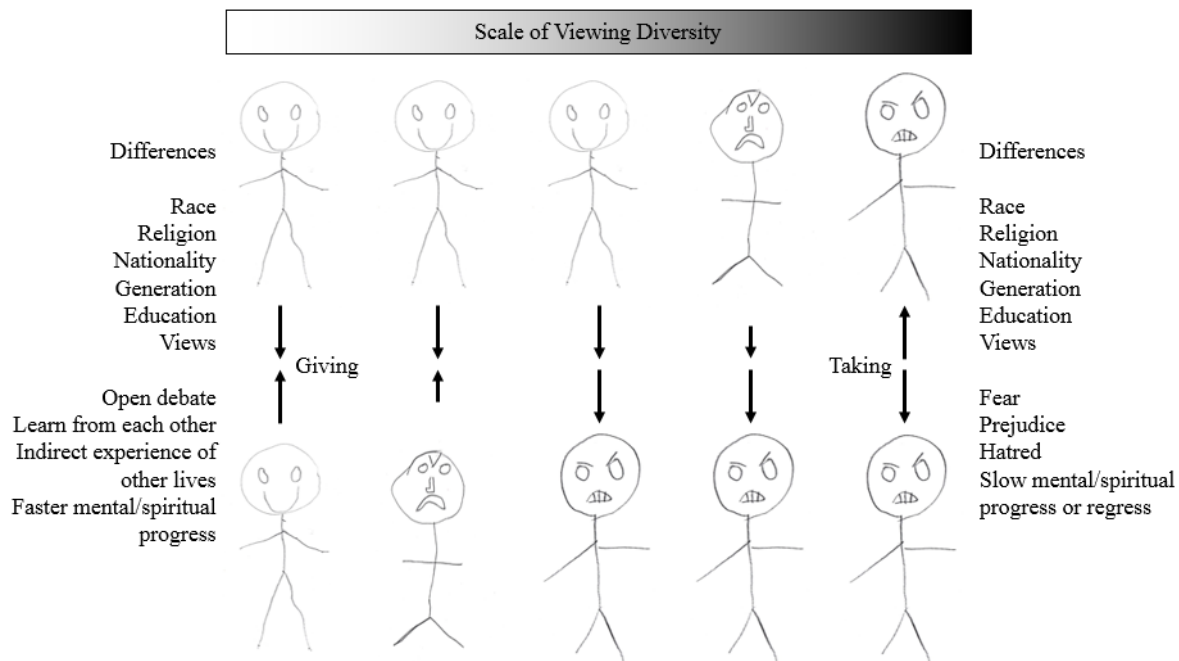

Figure 5

Minorities

We can think of identifying more differences between each other than the main ones listed above. We can add more features related to our appearance, such as height, body structure, hair colour, eye colour, voice. We can also add various preferences when it comes to activities, food, entertainment, hobby. We can slice groups of people into sub-groups and these sub-groups into smaller groups. If we go really deep into details, we will realise that we are the only one in this very specific group of people and there is nobody else who can fit here. We then realise the uniqueness of our life (personal experience). We also realise that each of us is indeed a minority.

How sensible is it for a certain group of people to claim and demand special rights reserved just for this specific group? Is this feasible at all? It seems unreasonable that one of us would claim special rights for him or her and receive them based on the fact of being a minority. It is totally unfair towards everyone else, and it is very likely to invade other people's freedom. We do not do it on an individual level because everyone knows that they just have to accept their life for what it is, and it is our own responsibility to make it better. However, we observe various groups of people demanding some special rights based on imaginary foundations. Can you think of a group of tall or short people demanding that houses, offices, cars and planes be made to fit their height? There is clearly some level of discrimination in terms of the design of buildings, means of transportation, or even clothing. Still, it is very well understood and accepted by all that these things are made to suit the majority of the population, who are people of average height, perhaps with some allowances to accommodate those whose height is further from the average.

People and their Impact

Everyone is driven by a certain set of interests, personal dreams, or goals. We all want a good life. For some of us, it means to have a family, a house, enjoy day-to-day life and family holidays. For others, it means to travel around the world and meet other cultures. The range and variety of specific personal objectives are large, and combinations are countless. Although there is definitely an overlap of many people's personal objectives in various areas, everyone's actions are individual and in isolation from others. Naturally, they are our personal dreams and objectives, and we often hesitate to share them with others.

A lot of us imagine that the evolution of humanity as a whole is a result of all those individual actions. It could be described as a group of random vectors (in size and direction) where each vector is specified by our personal dreams, goals and desires (direction) and the amount of focus and effort we put in to achieve them (size, length). Since these vectors are random in size and direction, we can easily imagine that the big picture is rather chaotic and the resulting force moving humanity towards its next stages of the evolution seems to be random in its direction and rather small in size or maybe even negligible. It means that our individual actions described above do not really have any significant impact on where we head to as humanity. For each individual action, there is likely another individual action of the opposite direction and similar strength. Even with two or more people going in the same direction, their actions are likely separated from each other. These people may not know about each other, or they often do not exchange information about their objectives to identify the common areas. The force or forces that drive our evolution as a whole come from a different source.

People, who in addition to their personal goals demonstrate other dreams, goals and desires that relate to larger groups of people or even whole humanity, are the driving force of our evolution. These are the people with dreams and vision that go far beyond their personal life. They are also focused and extremely determined to achieve these goals and turn their vision into reality. They are the leaders who share their dreams and opinions with other people in order to gain their support and cooperation in their efforts. They often form groups with other leaders, with whom they share common goals, and by doing this, enhance their force that pushes the world in a certain direction. Majority of the people do not have these attributes, or they suppress them by their own fear of criticism or by not believing in themselves enough. These people become supporters or opponents of the ideas proposed by the leaders, or they most often remain neutral. These people are the followers.

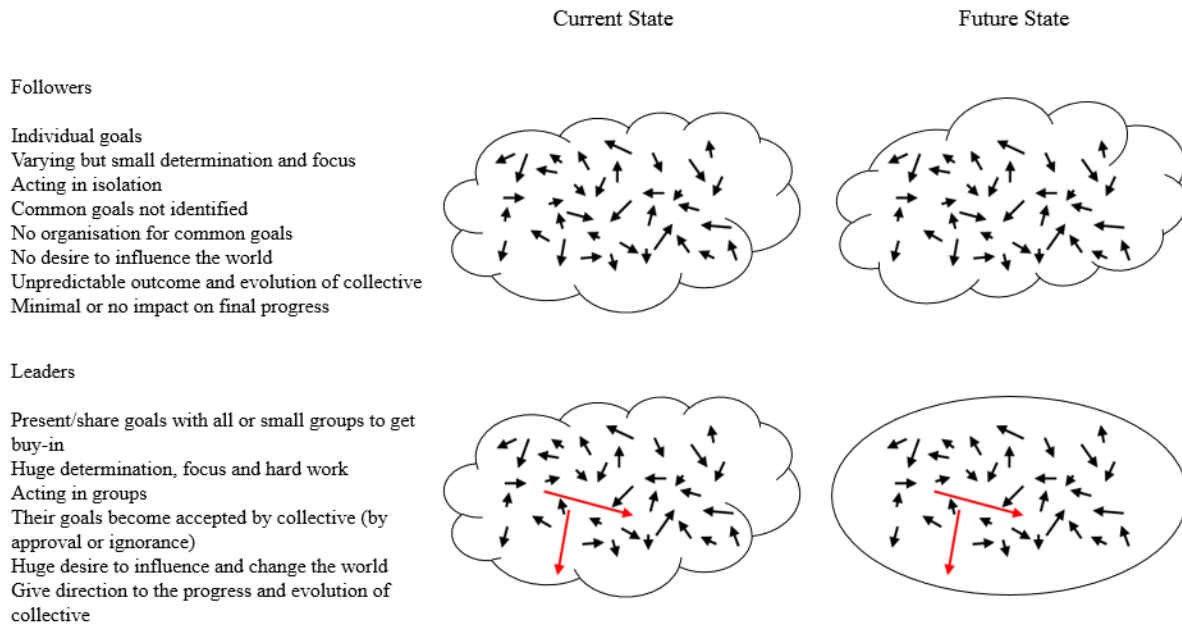

Figure 6

We have to understand now that it does not take many leaders to put their common idea in motion. They still have to put in a lot of effort and energy, but they are willing to do it because they can foresee in their minds the end result that is their goal. Since the majority of people are only focused on their individual goals, they either do not know about the goals of those leaders (by limited or no curiosity for matters beyond those directly having an impact on them), or they have a brief knowledge but do not care whether they will be achieved or not (they are unlikely to see these goals having an impact on them). Quite often, the followers accept and passively support the goals of the leaders because they see the leaders as the people with a higher level of knowledge, intelligence, or even authority.

This leads to the conclusion that the majority does not, in fact, interfere with the groups of leaders who shape the future of the world around us according to their own will.

Openness or Conspiracy

As we can imagine, we can have two extreme scenarios here, depending on the characteristics of the leaders being either good or evil. In the first case, all the leaders are good. Of course, in this situation, there is no threat to the followers at all, and most likely, everyone will benefit from the direction and results of such leadership. In the second case, all the leaders are evil. We then have an evil and powerful conspiracy against the uninformed and unaware followers. We may also have various evil groups conspiring against each other. The world led by the evil people goes in the direction of manipulation and control with some minor deviations from the main path due to different evil groups opposing each other in some areas. The obvious end result, in this case, is the evil world where the followers are imprisoned in total control by the evil group(s).

Depending on the technological advancement of humanity, such control may be impossible to overcome by any opposition because any slight movement against it can be easily detected and destroyed on the spot. Such a system also creates wide-spread fear amongst the population, and we know how fear can paralyse us from taking any reasonable action.

In reality, the world we live in is somewhere between these two extreme cases. We definitely have plenty of various groups of people working together towards their common goals. Some of them have good intentions, and some do not. Some of these groups operate on a low and local level while the others cover large areas and populations, whole countries, and even the whole world. Good examples are various world organisations.

The world we live in is also dynamic and continuously changing in this matter since the existing groups reform themselves, some groups disappear, and some new groups are formed. I suggest that you think about this, observe the world around us, research and analyse the information you get in order to evaluate for yourself: where on this scale humanity is right now and where we are heading to. Is the world going in the direction where all the people will live a good or better life, or is it going towards a tyranny, where a few groups will benefit while the majority will suffer? By doing so, you can assess for yourself whether conspiracies are real and became a threat to us or are just theories not worth our attention. Of course, you may not be able to gather all the necessary information. However, even incomplete knowledge supported by your own observation, learning from past experiences of humanity, and your own analysis will let you evaluate probabilities of various scenarios. This may be strong-enough evidence to give you a good understanding of the world around us. You may also be able to predict future events and the direction of the world's evolution.

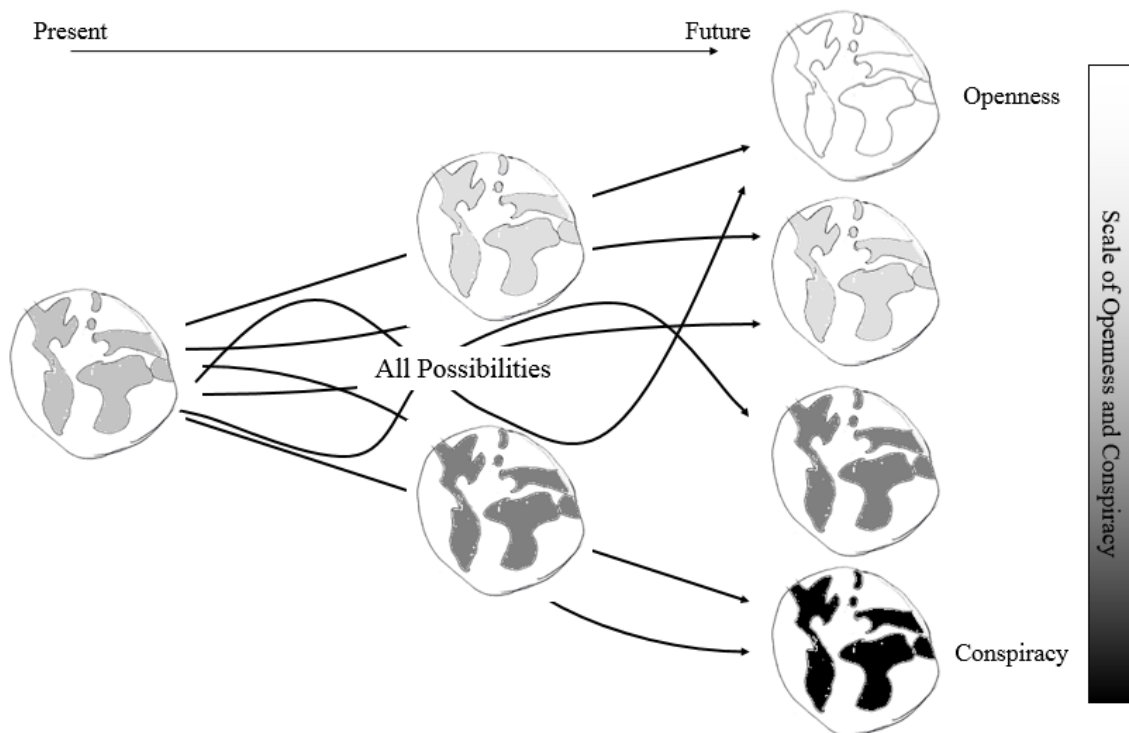

Figure 7

Capital

Current Definition

We have been taught that capital is a factor of production, alongside other factors such as natural resources (land, material), human resources (labour) and other inputs (entrepreneurship, management and knowledge). These categories represent both tangible and intangible factors, and when put together to work, result in goods and services offered for consumption. I am not convinced the current definition of capital captures the essence and true meaning of capital. All elements of production listed above, except natural resources, are secondary factors that come from the primary source. This source is human potential.

Correct Definition

The definition of a true capital is human potential in the form of imagination, creativity, and effort of the mind and body, resulting in a product or service that is valuable to another human.

Natural resources are subject to human potential. Without this potential, they are not utilised in an economic sense, and their real value remains undiscovered. It is also the human potential that identifies further value in natural resources along with technological development and a better understanding of what we call the material world. Some resources seem useless to us until we discover a technology that can utilise them to benefit us.

It is also important to notice that the capital only has a meaning if it results in something valued by another human. Otherwise, our imagination, creativity and effort to create something may be valuable to us, but meaningless and not noticed by others. It also emphasises the fact that interaction between humans is essential for the capital to reveal itself. It is related to our diverse world, where everyone is unique with their special talents, interests and skills. This diversity is a significant factor in human cooperation and interaction. It allows humanity to be an efficient economic system.

Our Hidden Power – True Capital

Any progress made by humanity has always been an outcome of the capital defined this way. Everything else, especially money, is only the tool we use in this process to operate more efficiently as a system. Over the years, decades, or even centuries, we have been misled to think of money or physical possessions as capital. This way of thinking takes away from us the realisation of a huge power that we have as human beings. It paralyses us as participants of the economy when we lack of wealth defined by the current dogma.

True Capitalism

The truth is that every human being has a vast amount of capital (potential). It starts with our talents when we are born and young. Everyone can expand it by learning, growing their knowledge and skills, and cooperating with others. All that's needed to unleash this real but hidden capital is a system of exchange based on solid principles – true capitalism. Such a system should be only a tool that allows all human beings easily and efficiently exchange fruits

of their potential. It has to serve humanity, not govern it. It means that what is possible to be done by a human because of their imagination and creativity cannot be limited or suppressed by the system of exchange. Exchanging fruits of our capital is our natural law, and it is only a subject to freedom of choice.

Producers and Consumers

When We Are Producers and When We Are Consumers

Producers are the people who create a product or service and offer it to others. Consumers are those who buy such a product or service and consume it. It is quite obvious that each of us is sometimes a producer and sometimes a consumer, maybe with some extreme cases of being a consumer all the time. We change these roles very often without realising it.

A very simple example: When an ordinary person gets up in the morning and gets ready for work, he or she uses products (food, clothes, toiletries), then drives or takes a train/bus to their workplace, all this being done as a consumer. While at work, he/she spends most of the time as a producer by offering his/her services to the employer. But while on lunch break, he/she switches to a consumer again. Then he/she goes home, perhaps does some shopping on the way (consumer). While at home, he/she usually carries out various tasks (producer) and maybe has some time to relax and watch TV or read (consumer).

Each of us lives their life with a balance of these two roles, and this balance is dynamic in nature. Of course, we would like to be just consumers and not to have to work. We could then spend our spare time on a hobby or something that we enjoy doing, which may make us producers anyway. There are also things that we do as producers, such as preparing a meal for a spouse or family. Though in these cases, we do it because we care about others, and we do not look at it as an exchange between producers and consumers. Some people successfully turned their interests and hobbies into businesses. These people are entrepreneurs who took a risk and decided to follow their dreams and passion. They seem to be much happier than those with ordinary jobs, and this is because they do not view it as an inevitable job but a pleasure and their purpose. Therefore, we can see that being a producer and consumer has a range of meanings in our interaction with each other.

The Role of Producers

The role of us as producers is to provide the best-optimised product or service in terms of quality and price so that it is attractive to consumers. This role is quite difficult because as producers, we have to satisfy consumers' expectations that can change any time. We have to work efficiently, often force ourselves to do certain things to provide a product or service that will be valued by the consumers. We have a competition who is in the same situation.

Competition increases the level of difficulty to become or remain a producer. But it also increases the satisfaction of consumers because they have more choices and the best product or service options available in the market. Once we switch to the role of a consumer, we can choose from this variety of products and services. We can research the market, ask questions

about various products and services. We decide whether we want to buy something now or later, from which producer we are going to buy, or we can change our mind and not buy it at all. From a producer's perspective, it creates uncertainty because nobody can guarantee that their products or services will find buyers. This is where the sacrifice we make as producers pays back when we become consumers. It is important to understand this because we can then look at the relationship between producer and consumer from both perspectives.

Balance and External Factors

It also means that any interference into this balance may have negative effects. For instance, if a government enforces some businesses to follow some rules, then their products or services will likely be more expensive because these businesses will have to bear an additional cost of complying with these rules. The cost will be then transferred onto prices. Consumers may then have some advantage (but not necessary) because of the businesses following these rules, but they will have to pay more for the same product or service than before. The behaviour of people as producers and consumers always finds a natural balance in the market. Once put out of the balance by some external factor, the market will adjust itself naturally (by people's behaviour) and find a new point of balance. Depending on the external factors, this new point of balance may not be as good (optimum) for the users of the market as before. Therefore, any regulations carry a big risk of causing deviation from the optimal point, of course, even the optimal point of balance is dynamic in time due to natural market changes, not regulations.

Limitations in Today's System

We all agree that it is not easy to become an independent producer (entrepreneur) and offer to others what we are passionate about. Majority of us are entrapped in a job that we hardly enjoy or maybe even hate. We have to pay our bills and have no savings. This stops us from leaving the current job to pursue our dreams. This situation is related to the way the current economy and monetary system work. There are limitations that make it impossible or very difficult to utilise our real hidden potential and be able to afford the products and services that we need or want. These limitations are usually a lack of what people call the capital (commonly defined as a factor of production). We often do not have large amounts of money or assets that would let us start a business. We may feel like we have all necessary skills, knowledge and definitely the passion to start doing something, but we cannot do it due to the limitations imposed by the system. This problem is common for many people.

In today's system, you have to find an investor who is willing to participate in your idea. Some investors do it to help others, but the main deciding factor for them is their own interest and expected future profit over the risk.

Unrestricted System

If the limitation of so-called capital was not a problem, what would stop us from trying and starting a business? If there were a system in which we were not bound by lack of money, after analysing all risks and potential benefits, we would have freedom of choice, regardless of whether we have funds or not, even jobless, homeless or disabled people could become active

in the economy because the system would only require true capital (potential) instead of money. Perhaps it may now sound insane and impossible, but after reading the next few chapters, you may change your opinion on this.

Current Monetary System

Naturally Evolved or Imposed

If you look at the monetary system that is currently in operation, you will most likely think that it is a result of a natural evolution of humanity and development of technology, society and economy. In fact, it is the result of an old master plan that has been put to work over many years by certain groups of people. It is a corrupt system designed to drain the human potential from the majority of people and feed its outcome (wealth) to these small groups of people. It has been done by deception. If you think it is impossible, please refer to the previous parts of this book where I described people's impact and conspiracy.

You should do some research and study for yourself about the monetary system, how it all started, the evolution of it, what is money, what are forms of money, what is fiat money, how it is created, who controls it, what is debt and who owes it to whom. If you dig deep enough, you will discover the true purpose of the current monetary system, i.e., the enslavement of the whole of humanity.

The Illusion and Monopoly

The principle, on which it is constructed is rather simple and what makes it look complex are all additions to it in the world of finance today. We need to understand that what an ordinary person today calls money is in fact numbers. We now hardly use fiat money such as coins and banknotes, and we mainly use our cards and phones for payments. These link to our bank accounts, where numbers represent how much money we have. This money is created by the banking system that consists of central banks and commercial banks. With the use of a fractional reserve system, the banking system can technically create unlimited amount of money (numbers) and lend it to its users (us). The only limitations are those imposed by the banking system itself in order to stabilise the effects of its own activity and avoid causing an obvious catastrophe of the system. This system's money has no objective value and it gains value because the users of this money find it useful or necessary to carry out their activities in the economy (exchange of goods and services). In this system, all the money is also a debt and we are only the users, who have to pay a fee (interest) for using it. While we create real wealth by producing goods and services and exchange them with others, the creators and owners of money consider the money to be their product and the fact of lending this product to us is considered by them as service, for which we pay the fee. One could argue that the banking system operates exactly as anyone else, e. g. telecommunications provider. However, we have to realise that even if we consider money as a product, it is a very special product that has unique properties and a huge impact on the whole economy. It is not a product that we consume.

First of all, the banking system has monopoly to create money. Even with various currencies it is a connected system controlled by a few. This system is really separated from the economy,

where people normally interact and exchange goods and services. It is only connected to the economy in order to provide the input and to receive the output. This system does not depend on people's actions in the market and the opposite occurs – people's economic activity is controlled by the money instead. Is it possible for a normal human economic activity to exist without money? Yes, it is called barter. Money is only a tool that makes people's economic interaction easier.

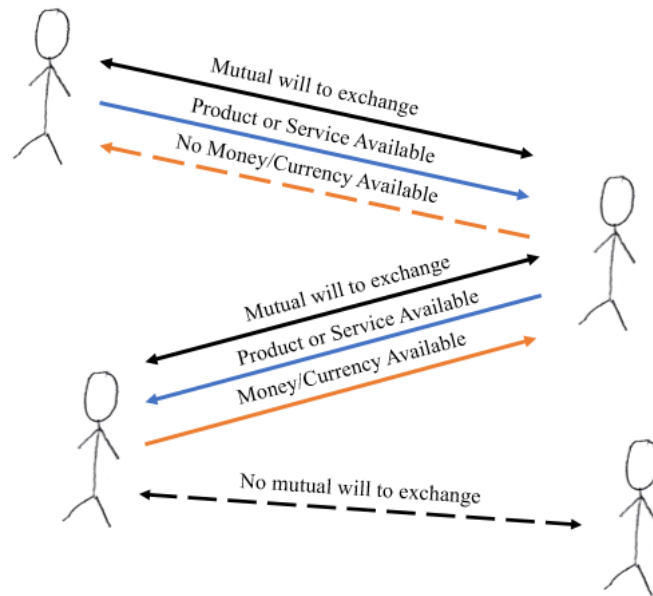

Figure 8

Prosperity and Crisis

By creating excess money and injecting it into the economy, the banking system can manipulate people's economic activity and artificially create the perception of prosperity (fish tank is full of water). In this case, people are more likely to receive loans, and their businesses receive stimulation to produce more of their products and services. Many of them expand because there is more demand in the market. Consumers have easy access to money because of low-interest rates (money supply valve open). Everyone seems to feel the positive effects of such stimulation. The first ones injected with this new money take advantage of buying businesses, products and services at the price that has not yet changed. Once the new money spreads out in the economy, the market stabilises itself by increasing prices on a global scale. It is called inflation. However, people do not realise, or they forget that this is where the crisis begins. This new money is lent, not given to people; therefore, it is a debt that will have to be paid back with interest later on. It is only a matter of time when the economy will experience troubles.

This money stimulation creates overproduction of goods and services. They have to be then sold; thus, the producers use marketing techniques (manipulation) to convince the consumers into buying them. People fall into this trick and spend the money on often unnecessary goods or services. We are told that humanity is now a threat to the environment because of pollution as an outcome of our activity. But we need to ask ourselves what the real cause of this pollution is. Is this because of us and our true needs, or is this because of our unnatural behaviour of overconsumption triggered in us through manipulation?

An important aspect of a long-term injection of excess money to the economy is inflation. As a result, humanity is used to the continuous increase in prices, GDP, salaries and other measures. This is somehow reasonable due to the increase of the world population and more goods and services available to everyone, but it does not represent the true growth. These measures only represent the volume of money (debt). What would happen if these measures were continuously decreasing? It would not necessarily mean a crisis. What is more important is the balance between these measures, regardless of whether they increase or decrease. If our salaries did not change while prices decreased, we would have a higher purchase power. The increase, however, is beneficial for the banking system as it can quietly expand its control over us through the growing debt. This is why the amount of money (debt) in the economy and these measures grow in the long-term.

The banking system operates in cycles, meaning that there is enough time from the moment the excess money is being injected to allow people and businesses to create real wealth. This wealth is then stolen by an artificially created economic crisis.

As much as the injection of money stimulates the economy to grow, the opposite happens when the banking system decides to increase interest rates (money supply valve close). By doing this, the banking system changes the direction the money flows. Now, the money is going to flow back from the economy to the banking system. The amount of debt being paid back becomes larger than the new money supplied to the economy. Since it is now difficult or impossible to get a loan and at the same time consumers, businesses and governments who took loans during prosperity period have to pay them back, the whole economy struggles to keep up with paying off the debt (fish tank is drained). It affects the whole population because we are all interconnected through everyday interaction and exchange in the market. Therefore, even those without loans experience the same negative effects. People and businesses start to compete more aggressively with each other in order to survive. Jobs disappear, employers cut costs where possible. Governments increase taxation, which additionally puts even more pressure on everyone. As a result, many businesses go bankrupt, most of them lose value, house prices drop, and people earn less. What seemed before to be a great period of growth was, in fact, an artificial bubble, the illusion of growth that was driven by the supply of money (in fact debt) instead of natural growth caused by natural economic activity of people. This is also a moment when the banking system can take over the real wealth built by people over the years or decades by repossessing it. The banking system and corrupted governments then pretend to fix the situation by doing exactly the same meaning, repeating the cycle.

This activity has been going for a long time. Many people do not understand why this happens, and they blame either the wrong people or mechanisms. With the increase of poverty, some extreme and dangerous ideologies become more popular amongst widely desperate population. Emotions and fear take over logic and reasoning. Only a few people look for the root cause of this disaster.

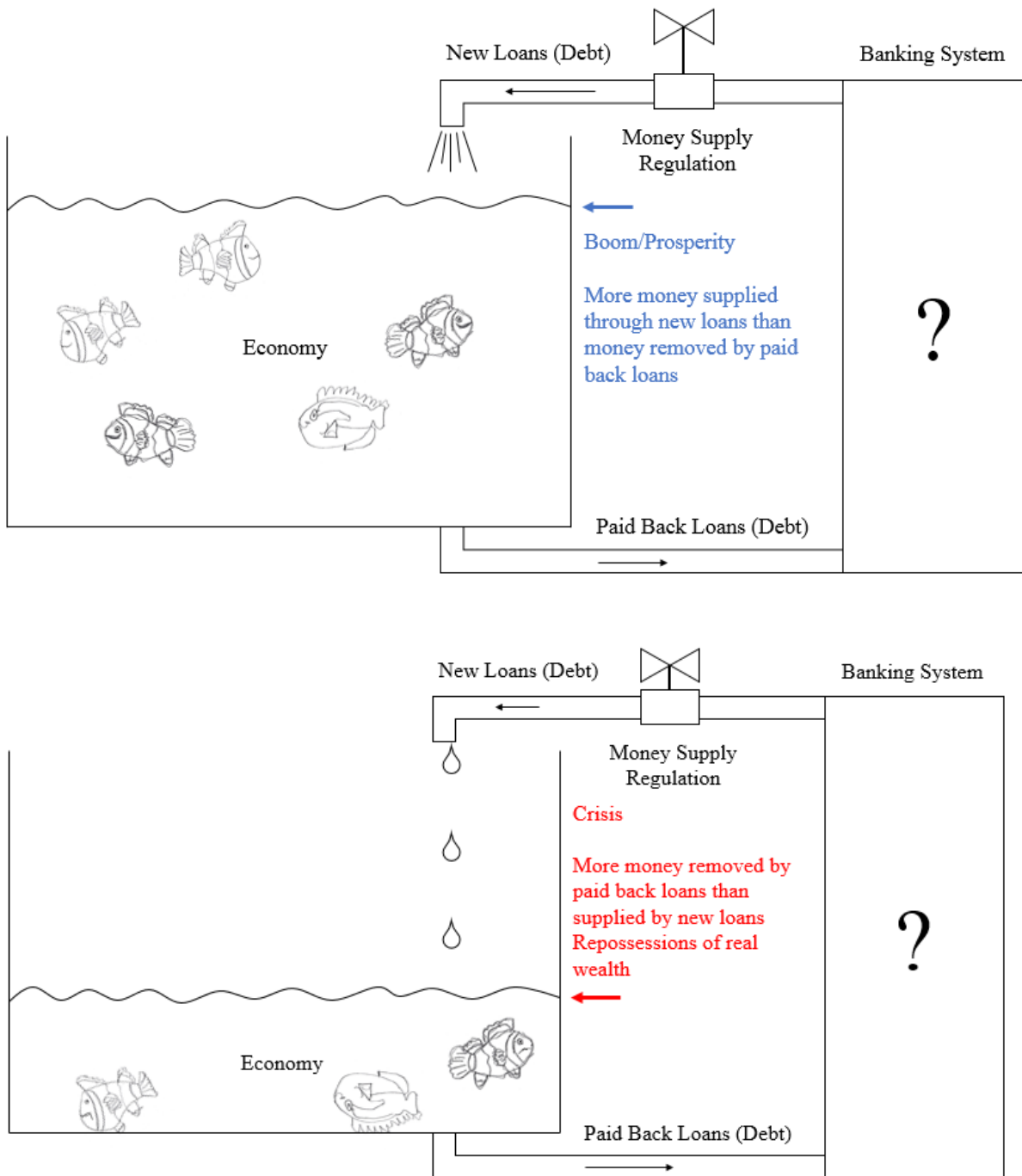

Figure 9. The question mark represents the origin of the money we use. In fact, there is nothing there except people's belief.

Theft of Our Capital and Wealth

We need to call it what it is – a global premeditated and coordinated theft and criminal activity by the ones controlling the banking system at the expense of the rest of us (the vast majority). Simply, it is a theft of our capital and wealth created by us over time.

Knowing how influential the banking system is, we can easily imagine how easy it is for this structure to control whole industries, including media, medicine and science, as well as policies and laws. All of them rely on money, and financing can be provided to those who conform with

the goals and ideology of this structure, while the alternative opinions are suppressed by not having access to money, thus being unable to reach a large number of people.

This structure can fund organisations that are aligned with its goals while trying to silence others. Considering that our world is somewhere between the two extreme worlds of good and evil, we can understand that this is highly probable. Depending on the level of evil in our world, we can suspect to what degree the goals of such a structure are achieved by means that an ordinary and good human considers immoral, disturbing, or even satanic. An ordinary human is very likely a subject to a coordinated manipulation and deception in every aspect of their lives without realising it at all. The reality around us must then be a construct designed and implemented entirely in line with the goals of this structure, not ours. The control of our economic life has been taken over through the banking system, and this became an efficient tool to take over the remaining aspects of our lives, to finally lead us into the system of total control and mental enslavement. The only shield against it that we still have is our freedom to think, our imagination and creativity. This, together with cooperation, can create the environment for a major change and escape from the enslavement.

Possible Monetary Systems

Government Control

We can think of many solutions to improve or replace this corrupt system described in the previous chapter. Many people believe and promote the idea that a government should control the money. However, this would only partially make sense. On the one hand, the purpose of the government is to represent the will of the people. This would suggest that the control of the monetary system should be in the hands of the government (monopoly). But we know this is wishful thinking. The reality is that by giving such control to the government, we will not address the root cause of the problem, and we will likely end up with a similarly corrupted system.

Competition

On the other hand, we know that unrestricted competition provides the best results, regardless of whether it is a product or service. Therefore, the best solution seems to be a system of multiple currencies that can be created by everyone and used by everyone else. In reality, this would not occur. Instead, there would be multiple systems set up freely by various people or organisations, including local communities or governments, or whole countries. We have examples of cryptocurrencies that do it to some extent. It does not really matter. What matters is that all these systems would offer service of providing money to their users while openly and freely competing amongst themselves.

It is quite clear that the systems that offer the best solution and are the most user-friendly would attract the majority of the users. The creators of these currencies and systems would set their own rules on how they operate, what is allowed and what is not. As you can imagine, the systems that offered the highest level of freedom and transparency would be the most attractive and popular. It is exactly the same as we now experience with a mobile phone or Internet

service, or just simply choosing where we shop. Therefore, one element of the solution is competition.

The second element is something that needs a little more introduction, and it is covered in the following chapters. For now, let us just ask ourselves: Do we need currency (money) as we understand it today?

Corruption

We all know what corruption is. We talk about it a lot since it occurs in various areas of our life, especially our governments, several institutions and public services. But do we go deep enough to look for the root cause of corruption? We may say it is the system; the system is corrupted. We may also say it is people. And this is true. We have two components of the problem.

Corrupt People

It is not much we can do regarding corrupted people. As it is described in the first chapters, everyone has the freedom to choose between good and evil. Corrupted people chose bad in this regard. We can hope that they will change and start choosing good, but we cannot forcefully change them. It is up to them to understand it and make a decision about what they do and who they want to be. We can only protect ourselves from their plots by taking counteractions that expose them and try to stop them from wrongdoing.

Corrupt System

When it comes to a system, there is much more we can do because every system is an imaginary construct with certain rules that we all agree to respect. But a system can be designed well or poorly. Why do we have corruption in public organisations and do not really see corruption in private organisations? (I am not talking here about the interface between private and public but purely private).

As an example, let us look at private and public health service. In the private health service, you call a doctor, book an appointment, visit a doctor, and pay for the service. It's exactly the same if you went to a restaurant for a meal. There is no corruption here because the whole process is transparent. If this doctor is too expensive, you look for a cheaper option. If this doctor is too busy, you find another one or wait. If you really want this doctor to see you sooner than he/she can, then maybe you have to pay an extra fee, but it is clear to you what options you have available and how much it is going to cost you.

In the case of the public system, you pay for your healthcare in the form of taxation. You have a limited choice of doctors because they are normally assigned to your area. You book your visit and have to wait in a queue. If you also want to see a specific doctor or you want to be seen sooner, the system does not give you any option. It is a one-size-fits-all system. If you decide to offer extra money in order to be seen sooner or to see a specific doctor, you then

corrupt the system! We all know you are likely to find someone working in this system to get easily corrupted. You will achieve the same that you would have achieved in the private system, but you act against the regulations as well as the person you bribed.

Therefore, corruption occurs if the system is designed in the way that one human is given the power to decide about another human's quality and aspects of life.

How to Fix Corruption

How to minimise or get rid of corruption in the system? Remove all potential opportunities for this to happen by taking away such power of one person over another. Redesign the system or scrap it and replace with a private system where the producers and consumers set their own rules, and there is a diversity of available options.

There are very good examples of organisations that specialise in certain areas, attract best people in those areas and offer certification for others who join them and represent the same set of values, knowledge and skills. These organisations are highly respected by ordinary people, experts, governments, and internationally. They are private organisations, and no authority or government dictates how they are set up and what rules they follow. Such organisations are good examples of how people can establish themselves without the involvement of governments. By offering valuable service to others and maintaining high standards, they are highly respected.

Public Services

Public services that we are used to, such as health, education and many others can operate in the exact same manner. We do not need governments to set our education standards. The real education experts are not in the government. They are amongst the public, and they should be free to operate without restrictions from the government. Their knowledge, skills and creativity together with free and open competition can provide the best value to all of us. There can be diversity and enough choice for everyone to be satisfied. The consumers, by expressing their requirements, will dictate what services are offered and how they are carried out. It can work exactly the same as going to a restaurant. By the way, can you imagine a Public Dining System ruled by the government? Do you think such a system would offer you good service? Do you think it would be better or worse than what we have now?

Public services offered by governments are always more expensive than those provided by private businesses. It is because the government has to consume some portion of the money paid for such service just for administration. Therefore, the remaining funds are only used for the actual service. If you add the cost of corruption, the funds for the service decrease further. It results in either much poorer service or higher price for the consumer. The government is just an inefficient and corrupt middle man that does not add any value. There is no real incentive within the government to improve it because they have monopoly. Even if there are private healthcare providers, they cannot fairly compete with the government-owned because the government sets the rules as well as participates in the market. This is an apparent conflict of interest.

Paradigm Shift

Take Ownership of Your Life

In order to change anything in the world we live in, we have to start with ourselves. It is easy to blame the circumstances or other people. We need to ask ourselves a question: Do I take ownership of my life? Or do I just follow the rules set by others and adjust my life to these rules not to breach them and put myself into trouble? This question is related to the first chapter of this book. How much of this world we live in now and its rules is the result of our free will and choices? How much impact on it do I have? Are we the creators of it or just followers of the very few who create this world according to their will and dictate the rules of this game? Is this what we want?

In the previous chapters, it has been briefly described how our current monetary system works and what other systems could exist. The future of this will depend on us and our actions.

No Need for Money

Money does not have to exist. We do not need money. Why do we keep thinking that in order to pay someone for a product or service, we need to have something upfront? If there were only two people in the world today, how would they start exchanging their wealth? Maybe they would exchange goods for goods as humanity did in the past. Perhaps they would use precious metals or other objects to exchange for goods. Finally, maybe they would come up with a very simple principle and transparent system.

Creative Approach

We need to take this approach, the approach of a creator with a totally new and fresh view of our world and life. If something has existed for years or centuries, it does not mean it is the only and best way. The progress of humanity requires from us a creative approach. We have plenty of capital, and we should utilise it. Therefore, it makes much more sense to start creating good solutions instead of fighting the existing bad ones. It makes more sense to use our time and energy on creating what we want, rather than trying to destroy what a very few created for their benefit. Let us stop waiting for the world leaders who will drive the change, hoping they will do it as we want and successfully. We have been taking this approach for too long. Let us all become leaders of these changes. Let us organise on various levels and increase our impact on the world, create it according to our will and make it comfortable for all. Let us show that we can do it better. Then, this small group of parasites will first resist but will later have to follow in order to survive in our creation. Once they realise that they cannot manipulate us any longer, they will have to change their attitude and join our good world.

Balanced Exchange System (BES)

The Principles

The system I propose is based on these simple principles:

Principle 1

The total balance in the whole system is always equal to 0.

It means that in this system, there is no need to create money upfront. This system tracks transactions and reflects them in the user account's balance (in/out or credit/debit). This is a common practice in the banking system called ledger, and there is no reason why every human cannot apply the same simple method. We have been tricked into assuming that we need money upfront, while the banking system follows this simple rule itself.

Principle 2

The only source of credit are humans.

It means that there is no institution such as a bank that is the only source of credit but the people themselves. People are the only source of wealth when they use their real capital (potential) and create products and services. Therefore, only people can be the source of credit in the monetary system. Credit is a positive balance (income) received in exchange for products or services. Debit is the opposite and means an item of debt (sum owed). Credit is the reflection of the capital (potential). Therefore, any human at any moment can be a source of credit.

Principle 3

The system always allows a wilful exchange between people.

It means that the system cannot stop two humans from exchanging wealth, products or services. As you know, in the current system, you need money first to be able to buy something. If you do not have money, you have to borrow it. In the BES, as long as there is a will from both sides of the exchange, a transaction is allowed. In other words, what is possible physically is also possible in the system.

The Meaning of Balance

Since the whole system always has 0 balance, it means that the sum of all accounts balances must be 0. Everyone starts with 0 balance. Once two people decide to exchange some wealth (e.g. property), product or service, the producer or seller transfers the goods to the consumer. The system reflects this by adding credit (positive value) to the producer's account and adding debit (negative value) to the consumer's account. The absolute value is equal to the price agreed between these two individuals.

Table 1

	Person A (seller)	Person B (buyer)	System Balance
Before transaction	0	0	0
After transaction	100	-100	0

Once there are more individual transactions amongst people, everyone’s account shows a history of their transactions and the final balance. It is exactly what you can see in your current bank account.

Table 2

	Person A	Person B	Person C	Person D	Person E	System Balance
Transaction 1	50	-50				0
Transaction 2			80	-80		0
Transaction 3				50	-50	0
Transaction 4		30			-30	0
Transaction 5	-40	40				0
Transaction 6	-20		20			0
Transaction 7			-10		10	0
Final Balance	-10	20	90	-30	-70	0

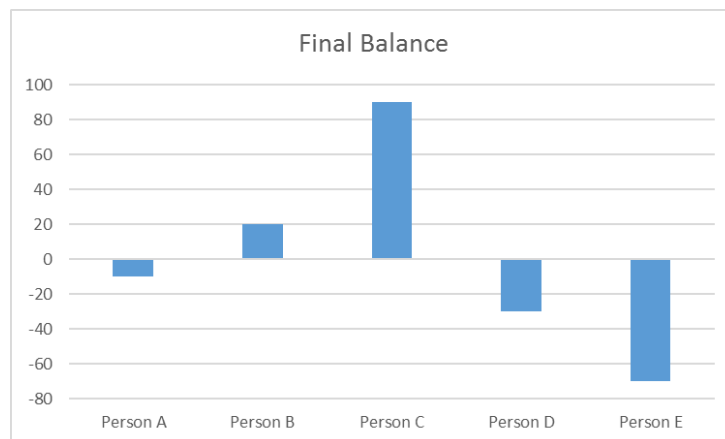

Figure 10

People with a positive balance (credit) have a dominant role as producer. Credit in their account has been created by their consumers and transferred to them in exchange for products or services. People with a negative balance (debit) have a dominant role as consumer. Since they purchased products or services, they had to create credit and transfer it to the sellers in exchange. Debit in their account is the record of this credit being transferred to the producers’ accounts. In other words, they owe to others. Since the sellers have already received credit, the consumers do not owe specifically to the sellers, from whom they purchased goods but they generally owe to the producers in the system. While producers created some value that others consumed, it means they contributed to the system. This is why they have received credit, which represents the potential of the consumers to create value and contribute to the system in future. The consumers have purchased goods and maybe have not produced anything at this

point or produced and sold goods of lower value than they purchased. Therefore, their accounts show a negative balance (debit).

There is nothing wrong with having a negative balance. It just means that you consumed more of a value created by others than a value you created and sold to others.

In the world of pure good, the people would have enough honesty to keep the balance close to 0. Some people, who tend to save money, would likely have a positive balance because they naturally limit their spending not to exceed their income. Others would have a negative balance because they spend more than they earn, hoping to pay it off from future income. In such a world of pure good, nobody would be concerned about others having negative balance because these people sooner or later would also contribute by offering some products or services to others.

It is natural that in some periods of our life, we have a need to spend more than we earn. For example, being a young adult, maybe starting a family, we need a place to live. It would be ideal to be able to purchase a home early in our life with the expectation that we would pay it off in the coming years or decades. What is most important is that this would be solely our decision, not the banking system, as it currently is.

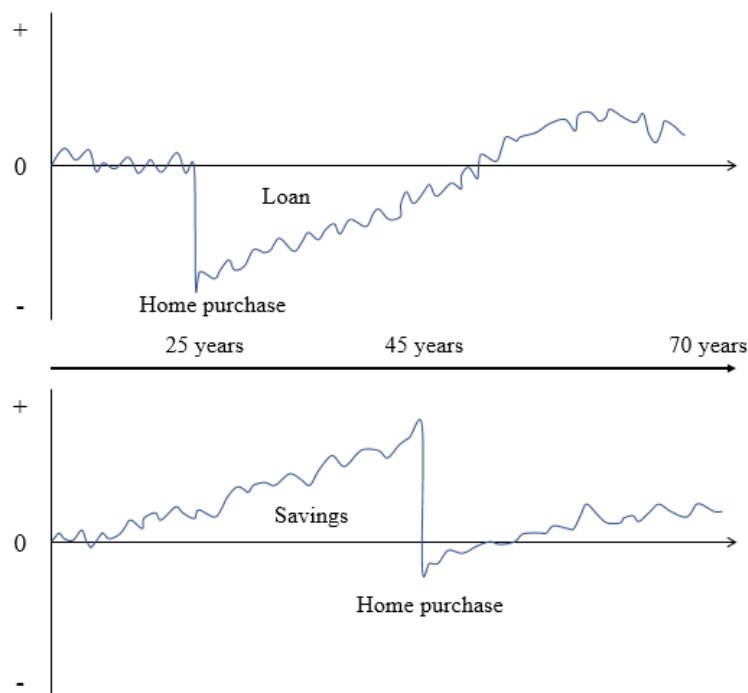

Figure 11. Example of two different scenarios, both equally possible in the BES.

Unit of Measure

I stated earlier that open and unrestricted competition is the best way for people to engage in the economy. This should also apply to the BES. However, it means that we could possibly have multiple systems based on these principles, each with a different unit of measure (currency). We would then have to deal with exchange rates between these systems. This would be more difficult to manage to ensure that the systems always remain at 0 balance.

Of course, when a transaction between two systems takes place, then both these systems go out of balance. This is because a user from one system receives credit, but debit is applied to a user in another system. If we then look at the balances separately, one is positive, and the other is negative. This is obviously against the first principle. But, the fact of a transaction taking place between two separate systems enforces us to look at both of them together in order to verify whether the first principle is satisfied. We can confirm that both systems considered together are in balance.

It also means that for all the systems interacting with each other, there has to be an umbrella system that can verify that the balance of all the interacting systems as a whole is equal to 0.

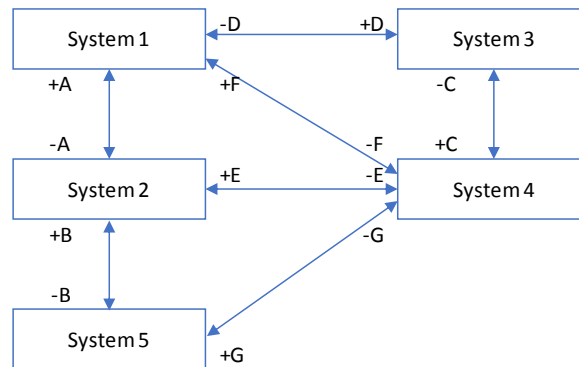

Figure 12

Table 3

	System 1	System 2	System 3	System 4	System 5
System 1		-A	+D	-F	
System 2	+A			-E	-B
System 3	-D			+C	
System 4	+F	+E	-C		+G
System 5		+B		-G	

This is not difficult with the current technology. The need for using exchange rates seems to be a nuisance. It is something we deal with in today's world without major issues, but I think we all agree that it would be much easier to use one unit of measure (currency).

The problem in the current system is that by using one world currency, we give the power of creating it to one formally defined entity. It is just going to make it easier for the banking system to control us as it will further strengthen the monopoly that it already has.

In the BES, one common unit of measure would bring benefit to all while there is no risk of losing the control. This is because of the second principle. In this system, regardless of the unit of measure, credit can only be created and transferred once a wilful transaction is made.

It would take some time for some people to adjust to a different unit of measure. Someone in the UK may be used to buying a bottle of water for £1 while someone in Colombia buys the same bottle of water for maybe 3,000 Colombian pesos.

It would be more convenient that all the people agree to use the same unit of measure. Of course, it does not mean that the same product will have identical price everywhere. Prices are

the result of the economy, meaning people's opportunities, abilities and behaviour. But having one standard unit of measure would make a global exchange simpler.

We could start with some guidelines to help people get used to typical values of products and services. People would adjust to it very quickly. We have examples where individuals in some countries comfortably use their local currency as well as USD or EUR because of foreign tourists visiting.

We could have similar initial guidelines to the ones shown below, to help people understand orders of magnitude with pricing, or we could just ask to use GBP, USD or EUR as a point of reference.

Bottle of water	1 BES unit
Smartphone/laptop	300-1,000 BES units
New car	8,000-60,000 BES units
House	80,000-500,000 BES units
Wage per hour	5-300 BES units

Benefits

There is a number of benefits that the BES brings to people.

1. Financial freedom. Nobody is restricted by the monetary system and its own policies. Everyone is sovereign to make financial decisions.
2. There is no money as such in the system; thus, no entity can inject an excess into the system, causing inflation. Nobody can manipulate the system to go into artificial cycles of prosperity and crisis.
3. There is no need to borrow from a bank since everyone has the same ability to create credit.
4. There is no situation of excess money to be invested/spent without the real need or lack of money for necessary investments.
5. People and real economy determine growth, growth speed and where investments are made.
6. People get educated that all economic activity is interconnected. Therefore, there is no free products or services unless producers want to give them away for free. Such education would expose anyone such as politicians promising free benefits since people would understand that this must lead to stealing wealth from others in the first place.
7. There is a natural limit for some people becoming extremely wealthy (huge positive balance) depending on the behaviour of other people. Credit can be only acquired by selling something that is valuable to another person. Unless something changes the owner, meaning that a transaction takes place, its value is not recorded in the system.
8. Although there may be a tendency amongst businesses to create a monopoly, there is always an unrestricted potential for competition to appear since it does not depend on the banking system decisions.

9. People can assess risk by themselves and take decisions to make larger purchases such as a home in periods of their life when they have not accumulated much credit or wealth yet (young people). They do not have to ask the banking system to allow them to do it.
10. People who are less lucky in their life can comfortably exist and function in the economy, because living with a negative account balance does not incur penalties or interest fee. It does not mean to irresponsibly take advantage of the system but to be able to live with dignity and have the opportunity to find the purpose of their life.
11. People can support each other by transferring credit to others as a gift. A value of the gift is deducted from the account balance of the person giving it and is added to the account balance of the person receiving it. This can enhance and encourage everyone's ability to help each other even if one is not wealthy him/herself. Even a person with a slightly negative balance could transfer a gift to another person whose balance is extremely negative.
12. Address poverty. As mentioned in point 11, people could help each other, regardless of their own account balance. It could work as a charity, where people transfer funds between their accounts. It would also cancel the current corrupted and wrong approach of governments stealing money from those who work in the form of tax and giving this money to those who do not. It is happening under the name of equality and reducing poverty. A principle of being helpful and support others is definitely good and valid, but should not be used as an excuse to forcefully transfer wealth from one to another. It is against the freedom of choice. If someone wants to be selfish, it is still their right to choose. I believe, however, that the majority of us are keen on sharing with others and it should be a voluntary act. It also gives the ones who receive help an understanding of the source of such support and gratitude towards these people rather than an attitude of claiming and demanding benefits from the government.

Feasibility in Real Life

You may now have a lot of questions about how this can be implemented in real life. The principles described earlier would be enough to create a transparent and robust system of exchange, only if all the people of the world were pure good. Since none of us is pure good and we tend to choose bad in some situations, unfortunately, we have to arm this system with some protection against attacks from dishonest, greedy or evil people.

The main concern in real life is what can be done if someone takes advantage of being just a consumer and does not contribute by being a producer. It would be someone with an extremely negative balance on their account. It would be equivalent to someone being deeply in debt (mortgage, loans, credit card borrowing). We have plenty of tools to deal with such issues in today's system. I believe that the tools and methods of dealing with it should be no different, especially when it is clear that a person is a dishonest user of the system. We could implement agreements and a general set of rules that govern operating in the system. Each system could define their own rules. By letting many different systems operate, through competition, consumers would narrow down all existing systems to maybe a few that are most attractive, transparent and offer the best security. I am convinced that such systems would be non-profit with minimum required rules to protect the users from fraud. In extreme cases, people can always use the justice system as it is currently done when dealing with unsettled debts.

I do not want to propose here detailed solutions to particular issues that may occur. This should be left for the people, the users of such systems to establish. In general, the rules would not be different than we follow now as a society. The purpose of proposing this system is mainly to demonstrate that we, the people, are the only source of credit (money). My opinion is that the most effective way for the people to coexist has been proven in history, and it is the conservative and free-market approach. The only missing aspect that I am trying to present here is how the monetary system itself should work in order to complement this approach. I believe this is the missing piece that can convince those who oppose the free market and capitalism because they worry about the vulnerable people who do not have the capital in its today's meaning. There are definitely similarities to well-known local systems, such as LETS. The main difference is though that the BES should have a global presence with the use of the latest technology such as distributed ledger technology or specifically blockchain. This would make it available to almost anyone and ensure decentralisation and security of all transactions and records. This technology has been proven in recent years, and we all have seen a big success of crypto-currencies. Even central banks are now trying to do the same with the main difference – the banking system remains the only creator of credit (money). Please note that the BES is also different from crypto-currencies (and gold-backed currency) mainly because of the source of value, which is human potential, as opposed to scarcity.

BES can work in parallel to the current monetary system. Since it is much more attractive than the current system, people are going to use it more often, and it will become their preferred system of exchange. This will naturally lead to the abandonment of the old corrupt system, which will ultimately implode and destroy itself, what it truly deserves.

Try It at Home

You can try the BES approach at home by playing the Monopoly game without using its money. Instead, prepare a sheet where you will be recording all transactions. Please note that you will need one account for what normally is the bank in order to transfer players' wages from it. Also, any purchase in the game will be then treated as buying a product (in this case, a property) from the bank (producer in this meaning). Other transactions such as taxes, fees and received benefits will take place between each player and the bank. Rent fees and secondary purchases of properties will be normally exchanged between the players, which will quite well simulate real-life scenarios. The players should probably agree about the additional rules of having a negative balance. Otherwise, each player would be buying everything and rapidly going into debt. This would spoil the game.

It only shows how the BES can work well if people were honest, but if they are not, then some rules are needed within the system in order to limit their greed and protect honest players from fraud.

You can play the game without using money at all. Start with all the players and the bank having zero balance. Keep the record of all transactions and account balances. You have to also always check that the total balance in the system is equal to zero.

Table 4

	Bank	Player 1	Player 2	Player 3	Player 4	Balance	Event
Acc Bal	-220	-16	-42	100	178	0	
	0	0	0	0	0	0	Start
	80	-80	0	0	0	0	Player 1 buys property for 80
	100	0	0	-100	0	0	Player 3 buys property for 100
	-800	200	200	200	200	0	Bank pays wage of 200 to each player
	0	6	-6	0	0	0	Player 2 pays rent fee of 6 to Player 1
	120	-120	0	0	0	0	Player 1 buys property for 120
	280	0	-280	0	0	0	Player 2 buys property for 280
	0	0	22	0	-22	0	Player 4 pays rent fee of 22 to Player 2
	0	-22	22	0	0	0	Player 1 pays rent fee of 22 to Player 2

Ownership

As you probably now realised, ownership is an essential part of this system. Every human, by using their capital, creates real wealth. It may be in the form of physical items or services. Once a physical item or a concept (intellectual property) is created, it naturally becomes the property of an individual. It can be valued, but in the BES, the system does not have any value assigned to it at this point. Once a product or service is offered to others, then potential buyers engage in negotiations with the producer. If both parties agree about the price, a transaction takes place. This is when the goods change owner.

Therefore, everyone has a natural right to be an owner, and it only depends on this person, whether they become an owner or not.

Shared Ownership

This concept is well understood, and all it means is that more than one person owns something. It can be applied to various areas of our life and economic interaction with others. It can exist on various levels, such as local, national, international and branch of industry. It is important to realise that shared ownership is the basis for the concepts presented below.

Cooperation Instead of Corporation

We live surrounded by corporations that are legally treated as persons. They usually have multiple owners (shareholders) and a board of directors who manage them in order to achieve maximum profit. This is what the owners expect. However, this concept leads to unexpected results. Although the people who own and run corporations usually do not have bad intentions towards the rest of us, they tend to create monsters (legal persons) without a soul. Some people, such as aforementioned shareholders, benefit from it by receiving a dividend.

In many instances also, the consumers benefit from a good quality and cheap product. On the other hand, the employees of such corporations are often dissatisfied and do not feel to be respected or valued by these soulless entities. It is worth to mention that majority of

shareholders are people and other corporations, for whom profit is the most important factor. They rarely care about what these corporations offer and how they treat their employees, local communities or environment. So, this is quite an unfortunate situation, where perhaps good intentions result in greedy and often inhuman entities that over time become very powerful, thanks to the current monetary system.

As an alternative view, I want to present a different approach. In the BES, it would be rather difficult for one person to create a huge business such as a corporation. The system would rather require many people sharing a common idea to come together and put their capital into such a big enterprise. Later on, they could attract more investors, who are ordinary people too, to invest their capital into it. It would form something similar to now widely spread crowdfunding. Since collaboration between people is a critical factor for this to happen, I think it could be called cooperation. It could perhaps have its own legal entity, but in terms of finance, all involved people should be liable for all activity carried out by such entity.

From the system balance perspective, it would be unwise to allow that the balance of such entity's account is not linked with the accounts of its owners. This would create a flaw in the system, where the owners could avoid personal liability while the entity goes bankrupt (extreme negative balance). Others, having claims against such entity would find no compensation in such circumstances. Having all the owners financially accountable according to their portion of ownership, the claimants could find compensation. This approach also enforces the shareholders to take moral responsibility for the actions taken by such entity.

Please think of this and how it currently works in the case of limited companies. A dishonest person, who somehow gains trust from the banking system, can run several limited companies, employ hundreds or thousands of people and get paid a large amount of money as a director's salary and dividend while at the same time all these businesses may be generating losses. This person's personal wealth is protected and legally separated from their businesses. As long as the banking system does not repossess these businesses, the process continues. It seems very unfair, especially that this person who comes across as a wealthy and successful entrepreneur may, in fact, be totally bankrupt and poorer than many ordinary people who have simple jobs and live honestly and humbly.

Government

In line with the concept of cooperation, I want to propose a new concept of the government. It can apply to any local as well as central government.

Please note that the government is just a concept agreed by a population of people. They agree on how the government is formed, what functions it has, and what it can or cannot do. The vast majority of people respect this agreement, and this is why we have such a structure rather than anarchy. However, we all know that the people who form our governments are very often dishonest and do not have the same respect for this agreement. They take advantage of this and manipulate the rest by trying to persuade them that they have authority over the public. This is

only true as long as the public keeps respecting this agreement, even though it has been breached by the imposters.

If you were placed on a deserted island with a member of your government, would you still consider this person to be an authority? Or would you rather view this situation as you both are equal and exactly the same laws apply to either of you? The concept of the government or authority of one man over another is just an imaginary construct and agreement between the people. It does not mean we do not need governments, but the way we view them should be that the public appoints certain people to form the government in order to serve the public and manage common matters, rather than dictate.

Government has evolved over the years from a council of elders or wise men in tribes, through monarchies to modern political systems such as democracy or now openly promoted technocracy. All these systems have pros and cons. It is important to emphasise that these are political, not economic systems. There is, however, one common influencing factor that is the monetary system. All political systems are built with the human population as their base, but they rarely serve their populations. The reason is that in the current monetary system, money has much more power than people's opinions. I am sure we can have no reliable political system if we first do not address the monetary system.

If we look closely at what is usually discussed amongst politicians and ordinary people, we realise that they do not argue or discuss so much about the matters such as general country policy, foreign policy, military policy. The main topic of any conversation is directly related to money and the distribution of wealth. Healthcare, welfare, taxes, benefits, education system, salaries and others – it is all about the money with a dose of ideology from some groups.

The way I see to address this is that each country should be a cooperation of its people. Each human, regardless of their age, should be a shareholder (co-owner) of this cooperation. I leave it to an open discussion about whether this should apply to citizens only or all residents. The main point is that the people should be aware of it and should formally be the owners. It means the people own all their country's resources, and they have a direct influence on the economy and decisions regarding these resources. This is on a local and whole country level. The way to achieve it would be to assign one share (as a fraction, not a nominal value) of the country's natural resources to its every resident (or citizen).

On a local level, residents would be assigned shares to other common wealth, such as infrastructure, public factories, public areas and buildings. It is privatisation by making people the owners as opposed to selling wealth to one investor, usually the finance sector owned by the banking system. It is also in opposition to Marxism where ownership is not clearly defined, and in fact, a government becomes the sole owner of all country's resources and wealth. In the country, as cooperation, the people would receive shares of various public entities and could keep them or sell them to others, except the country level share of natural resources. This is to ensure that the people remain a sovereign in their own land and would open opportunities for them to engage in businesses and initiatives that are of their interest.

The BES would allow the people to freely invest their capital as well. This move would cleanse the current system from the governments behaving like the only owners of this wealth. For all this to happen there has to be a common understanding of this matter. Only then will there be enough power and support from ordinary people to claim the ownership. Therefore, it all

depends on the people educating each other on matters such as law, common law, free market, true capitalism, economy, monetary systems and BES.

Only on this basis, where people are financially free, can we try to build a reliable government controlled by the free people.

Crowdfunding as Taxation

We all know that we cannot avoid taxation. It is obvious that we have to pay taxes in order to have road infrastructure, military or police. We have, however, let our governments grow to an enormous size and take over those aspects of our lives and economic activity, where they should have never been allowed. The role of the government should be kept to a minimum. Our economic activity should always be protected from government influence. This is us who have power, and we should always keep it.

I view taxation as a form of crowdfunding. We can agree, as a society, that we all pay certain taxes to maintain the minimal government, military and police to protect our common wealth. This would not be a problem at all with the BES because everyone, even jobless people, would be able to contribute.

When it comes to large investments that currently are decided by the governments together with big corporations, in fact, owned by the banking system, we should utilise a concept of crowdfunding. It means that anyone could propose an idea and share it (Internet platform) and people interested in this idea would support it with their funds (capital). It could be a road, hospital, school, or any other project. Each project would be managed by either a hired company or a management team selected by the investors. I only simply present the concept while detailed solutions are already well known to people.

This approach would totally change the way we see public investments. We would become more involved because we would know that we have the decision power and control over these activities. There would also be no limit to what we can imagine and achieve working this way together.

Public Services as Crowdfunding

In line with this approach, any public service would start with an idea and its success would depend on the decisions of the investors (shareholders of such enterprise amongst ordinary people) and how many customers (other ordinary people) it attracts. It also has a huge benefit that our capital and wealth would not be wasted or stolen by a corrupt government because the decision process would not go through the government members at all.

Various groups of people would be coming up with different ideas, and we would have a variety of solutions. This would allow our diverse population to grow freely as they want. Better solutions would be copied by others and would improve the overall effectiveness of our public (in fact, private and owned by many) services.

Something for Socialists

People who support socialism and promote the idea of systematically helping the most vulnerable can also find what I described above as an attractive solution. To all socialists, you may now realise that your concepts can be freely implemented in such a system and include all the people who are willing to participate in your concept. What you call public services that you want your governments to guarantee are in fact privately-owned (by many shareholders including you) enterprises that offer services that you, the collective, agreed upon. You then have even better control of this service as you are the co-owner and you do not have to waste your time on arguing your point in political debates. From the conservative perspective, this is fully in line with the idea of free choice and free market as your enterprise does not interfere with other people's lives and will.

Universal Basic Income

The idea of universal basic income may sound appealing to some people, especially those struggling financially. With the technology developing very fast, robotics and AI being available in more areas of our life and economy, a lot of us see a threat to their jobs and income. However, the UBI is not a reasonable solution because most of the people would lose economic freedom and rely on the state. It is clearly a path to fulfilling dreams of the Marxists. You probably know by now what the good and feasible solution is. It is the power of your true capital in a fair monetary system, shared ownership and cooperation. You can utilise your true capital in such a system without initial funding. As a shareholder, you are entitled to receiving a dividend, as long as the business generates profit. It is in your interest that the business is successful, so you support it. You are empowered and feel connection and responsibility. In the UBI system, people will instead take the approach of powerless beggars without any feeling of responsibility in the economy. In fact, the state will treat them as useless mass and slaves.

Government

I hope you understood the concepts presented in the previous chapter. This should dramatically change how we see the role of the government. If we, the people, have financial freedom, thanks to the proposed BES, then we can address most of our problems directly. We can then realise that the majority of people are not really so much interested in what the minimal government is required to do. These are matters of general policies of the country not related to our economy and day-to-day life. I think that only a small fraction of the population is really interested in discussing and debating these policies. In fact, only a few would have enough knowledge to be willing to actively participate in such debates. Let us look at diplomacy. How many of us have knowledge, skills or experience to comfortably discuss it? We may have some subjective opinion or feeling, but it does not make us experts in this matter. Perhaps we would like real experts to discuss this amongst themselves so that we can hear different views and support the opinions closest to our hearts and feelings.

Dynamic Control

This is where the concept of dynamic control of the government comes. Instead of having elections every few years, when politicians beg for our votes and often promise unrealistic things to be done, to finally abandon their promises once elected and make us look like fools, I propose that:

1. Any person can propose an idea or concept to the public on the dedicated Internet platform(s).
2. Every shareholder of the country has to contribute an agreed amount of credit towards the candidates or current parliament members. The amount can be paid monthly, weekly or bi-weekly, and it becomes the wage of each supported candidate or member of parliament.
3. People who are interested in the country's policies look at the proposed ideas and support the ones they agree with by directing their funds (see point 2) to the relevant candidates (see point 1). This way, the most popular ideas receive the most financial support.
4. The top 100 (number to be agreed by the people) candidates with their ideas form a parliament, where they can openly present their ideas and debate them.
5. Funding from people, who do not support a specific idea would be distributed equally amongst the members of parliament.
6. From the members of parliament (the top 100), a government is formed. It could be according to the position in the list of top 100 or could be voted by the 100 members of parliament. This is because some people have good ideas, but others are better at implementing them. Therefore, active and dynamic people should be in the government.
7. At any point in time, any of the 100 members of parliament can lose their mandate simply by moving below the top 100 in the list and be replaced by a new person who climbs up higher than them. This is determined by the funding from the people, and it is a continuous and dynamic process. This is to ensure that the best ideas are discussed and that the members of parliament who do not work towards their promises can be easily disqualified and removed from the parliament and government. This would also work if a member of parliament or the government was caught with fraud or some immoral activity. It would also be preferable that the account balance and activity of each member of parliament is public. Since they decided to take on such position, full transparency should be required from them.
8. Members of parliament, who remain in the top 100 for a long time due to their values, honesty, hard work and public mission become members of the council of wise men (experts). This council could have 10-20 seats. They are highly respected members of parliament and the public.
9. The ideas that have most public support are verified by the council. The experts, together with the high court (that is established separately), would verify whether a new concept can be implemented without conflict with the current law and what the possible consequences of such implementation would be. At this point, it is not always about new ideas but also the agreement with the natural law, stability, robustness and reliability of the parliament and country's policies. All debates and decisions should be publicly open so that the people are fully aware and at any time have the power to stop funding certain members and move their funding to support other candidates.

10. The government implements the idea once it has been approved by the council of wise men and verified by the high court.

Experts, Not Politicians

Although this concept promotes a dynamic way of “electing” people, in the long term, some balance can be achieved, and the highly respected members of parliament would likely serve many years while there would be more movement in the second half of the top 100.

Such an approach does not require that people form political parties in order to get funding either from the government or some lobbyists. Any person can become a member of parliament as long as they get support from ordinary people. Majority of ordinary people would not normally be interested unless some controversial matters are being proposed and discussed. Candidates would need to promote their ideas to the public to get their attention and support.

This approach also creates an environment for experts being able to participate in defining the country’s policies rather than random people looking for benefits of being a member of parliament, or unqualified politicians who are good at talking but not fulfilling their promises.

Council of Wisemen

A system like this that promotes and rewards people of good heart and intentions would result in natural emergence of Council of Wisemen. This board would protect the natural law and order of the country since its members would be highly supported and funded by the majority of the people. This council would likely become the most important body that determines the general direction of how the country evolves as one organism.

Final Note

I hope I have made you think about things that you did not pay much attention to before because of the busy life that we all live. The purpose of this book was to make you stop for a moment and look at the world around you more closely, maybe from a different perspective than you usually do.

Nothing in this world happens accidentally. Each of us has some input into it. It is important to realise that we, humans, have huge power. This is the power of our thoughts, imagination and creativity. We have been, however, divided for a very long time, and this makes us use this power against each other, either knowingly or not.

It is now time for honesty and cooperation so that our power can be aligned and multiplied in the direction that we all wisely choose, to create the world of ours.